

# Columbia®

The FL1000-SW from Columbia combines a rugged, heavy-duty small footprint palletizer with the added functionality of a fully integrated, industry proven stretch wrapper. The FL1000-SW can simultaneously stack and stretch wrap a wide variety of package types, including cases, trays, totes, film only and display packs from a variety of industries including canned and frozen foods, beverage, pharmaceutical and many more. The FL1000-SW palletizes 10 cases per minute or more, depending on case size and pallet pattern. Like all heavy-duty Columbia Machine palletizers the FL1000-SW has a reliable welded frame that is "built to last" and is EASY TO OPERATE.

FL1000-SW



## FEATURES

- Fully automatic with integrated stretch wrapper
- Category 3 safety circuits
- UL approved or CSA certified control panel
- Easy-to-operate with Columbia's Product Manager software
- Infeed tunnel & discharge light curtains
- Flexible, modular layout
- Small footprint
- Convenient floor level operation
- On board I/O electrical connections with ethernet enabled PLC
- Integrated automatic hoist safety pins
- Maintenance friendly access doors
- Online parts ordering at [www.palletizing.com](http://www.palletizing.com)
- 24-Hour parts and service hotline  
[1.800.628.5065](tel:18006285065)

To view a video of the **FL1000-SW** in operation and for more information on Columbia's complete line of palletizers, please visit [www.palletizing.com](http://www.palletizing.com) or call toll-free at [1.800.628.4065](tel:18006284065) / direct at [1.360.694.1501](tel:13606941501).

# FL1000-SW

## Common Palletizer Layouts

- ① **Infeed**
- ② **Palletizer**
- ③ **Pallet Dispenser**
- ④ **Discharge**
- ⑤ **Stretch Wrapper**

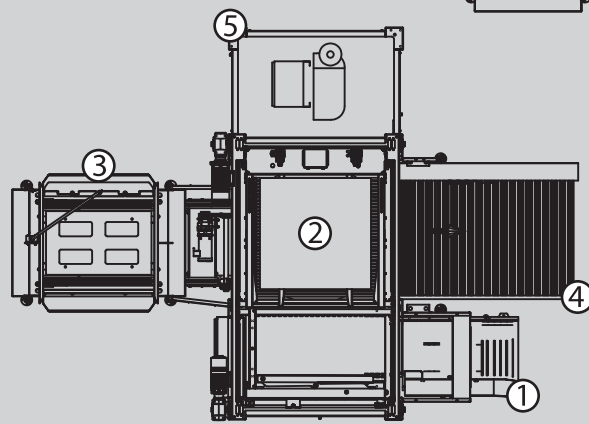
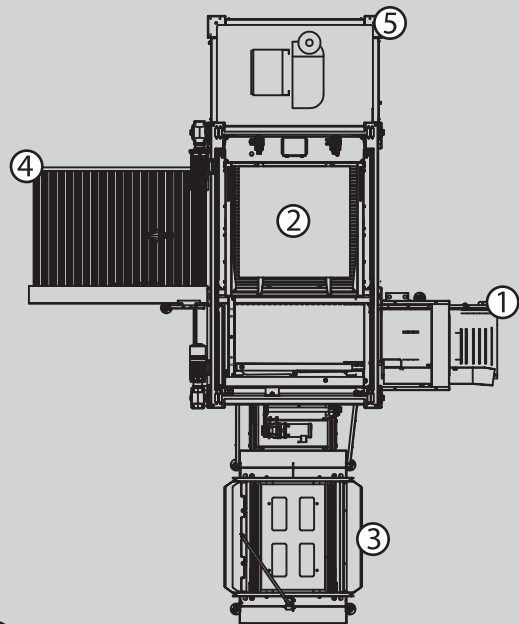
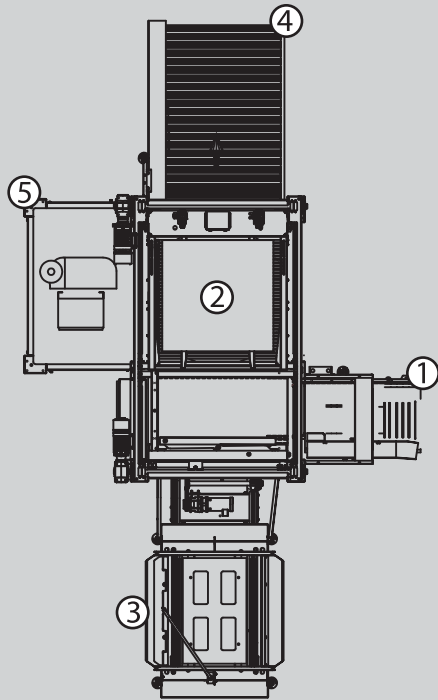

### COMMON OPTIONS

- Wireless controls interface
- Labels-out stacking
- Speed enhancement upgrades
- Soft product turning
- FDA accepted stainless steel paint
- Upsteam and downstream conveyor and interfacing
- Discharge conveyor
- Tie/Cap/Slip sheet dispenser

*Columbia*

[www.palletizing.com](http://www.palletizing.com)